



SAFETY NOTICE

110002

Date: June 27, 2011

Models and Serial Numbers Affected:

S-40 : 832 to 16027

S-45 : 832 to 16027

Subject: Floor Loading Information

Allowable Hours: 30 minutes

Issue:

Genie Industries has determined that the above referenced machines were produced with the wrong floor loading information in the operator's manuals and on the decals. This information indicates that the maximum wheel load is less than the actual maximum wheel load. **Incorrect floor loading information may result in the user operating the machine on a surface that is not capable of supporting the maximum wheel load.**

Action Required:

This bulletin requires replacement of the operating instructions manual and wheel load decals on the above referenced machines.

1. Locate all machines within the serial number ranges shown above.

Note: Enclosed is a list of affected machines under your account.

2. Locate and destroy any hard copies or electronic files in your inventory for the operator's manuals listed below:

P/N 43645 (2nd edition, 8th printing and previous versions)

P/N 82500 (3rd edition, 3rd printing and previous versions)

P/N 1000056 (4th edition, 2nd printing and previous versions)

P/N 133027 (5th edition, 1st printing)

P/N 133026 (5th edition, 1st printing)

P/N 133552 (6th edition, 1st printing)

Note: You can download the latest version of the Operating Instructions Manual from the Genie website located @ http://www.genieindustries.com/operator_manuals.asp

SAFETY NOTICE

110002

3. Locate and destroy the following wheel load decals on the machine and in your inventory.

P/N 82588

P/N 82629

4. Using the table in the attached Parts Order Form, determine the Decal/Operator's Manual kit for your machine.
5. Completely fill out the kit Parts Order Form and return to Genie's Parts Department to receive the Decal/Operator's Manual Kit for your machine at no cost.

Note: You may continue using the machines affected by this safety notice under the following conditions:

**Models S-40 : on surfaces that can support a wheel load up to
6700 lbs / 3040 kg.**

**Models S-45 : on surfaces that can support a wheel load up to
8500 lbs / 3855 kg.**

6. Upon receipt of the kit, replace the decal and the Operator's Manual on your machine.

Replacement of the operator's manual and decals must take place as soon as possible, but no later than 30 days from receipt of parts.

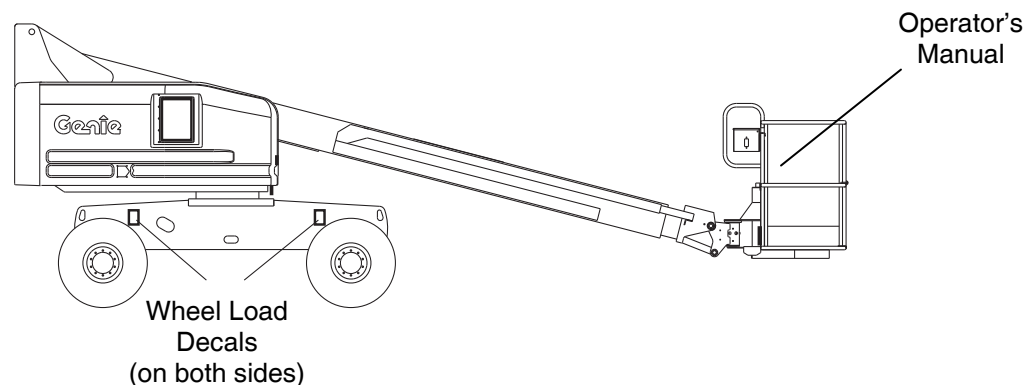

7. Fill out and sign the Completion Form included in the Parts Kit and fax to Genie's warranty department to verify that this safety notice has been completed.
8. Contact Genie's Service Parts department to receive credit for destroyed decals from your inventory.



SAFETY NOTICE

110002

Warranty:

The labor and travel miles required to perform this inspection and installation are covered under the provisions of our warranty agreement. Labor for each affected machine will be paid at a rate of \$60.00 U.S. per hour and travel at a rate of \$.50 U.S. per mile, converted into the currency of the appropriate country at the time of payment.

If you are the owner of an affected machine and are not an authorized Genie dealer, please contact your nearest Genie dealer for assistance with this safety notice. Only Genie Authorized Dealers will be reimbursed for labor or any other costs associated with this bulletin under the provisions of our standard warranty terms and conditions.

Genie and ANSI requires that the seller of a Genie machine report to Genie the model and serial number of each machine sold, as well as the name, address, and telephone number of the new owner, within 60 days of the sale. OSHA and ANSI also require that the manufacturer's safety notices be completed. It is your responsibility to communicate this important information to all machine owners and applicable branches. If you require additional copies of this safety notice or have any questions, please contact Genie's service department at:

United States	800-536-1800
Canada	425-881-1800
Europe	+31 653 221 908
Australia	61 733751660
All other locations	001-425-881-1800

Enclosures:

Machine List Report
New Owner Update Form
Parts Order Form



Safety Notice 110002

New Owner Update Form

(for updating machine owner information only)

Genie and ANSI requires that the seller of a Genie machine report to Genie the model and serial number of each machine sold, as well as the name, address, and telephone number of the new owner, within 60 days of the sale.

- If you have sold a machine, list the complete model and serial number (example: S40-7190 or S4007-11569 or S45-6136 or S4508-14071) and the name, address and phone number of the new owner.

New Owner Information:

	Machine 1	Machine 2	Machine 3
Model*	_____	_____	_____
Serial Number*	_____	_____	_____
Owner Name*	_____	_____	_____
Address 1*	_____	_____	_____
Address 2	_____	_____	_____
City/State/Zip*	_____	_____	_____
Phone Number*	_____	_____	_____
Contact Person	_____	_____	_____

* *Required fields.*

Seller Information:

Date: _____

Company Name: _____

Account #: _____

Address: _____

(street) _____

(city) _____

State, zip code _____

Phone #: _____

- List any machines that could not be inspected or repaired because of the following:

Model & Serial Number	Scrapped	Exported	Stolen	Others (explain)
_____	-	-	-	-
_____	-	-	-	-
_____	-	-	-	-
_____	-	-	-	-

Fax to: United States 877-738-7530
 Canada 425-498-7530
 All other locations 001-425-498-7530



Safety Notice 110002

Parts Order Form

Fax this form to Genie Industries to receive the indicated *Operator's Manual / Decal Kit* for your machine. List the model and serial number of each affected machine.

Serial Range	Model	Kit P/N (English)	Translations				
			Chinese Simplified	French	Japanese	Korean	Spanish
from 832 to 7189	S-40	229352	CS	FR	N/A	KO	SP
	S-45	229353	CS	FR	N/A	KO	SP
from 7190 to 9752	S-40	228844	N/A	FR	JA	KO	SP
	S-45	228845	N/A	FR	JA	KO	SP
from 9753 to 14677	S-40	228846	N/A	FR	JA	N/A	SP
	S-45	228847	N/A	FR	JA	N/A	SP
from 14678 to 16027	S-40	228836	N/A	FR	N/A	N/A	SP
	S-45	228837	N/A	FR	N/A	N/A	SP

*N/A – not available

- **Please list the complete model and serial number** (example: S40-7190 or S4007-11569 or S45-6136 or S4508-14071) or Z3406-5064). Leave "Translation" column blank if ordering the English version of the kit.

Model	Serial Number	Kit P/N	Translation
_____	_____	_____	_____
_____	_____	_____	_____
_____	_____	_____	_____
_____	_____	_____	_____
_____	_____	_____	_____
_____	_____	_____	_____
_____	_____	_____	_____
_____	_____	_____	_____
_____	_____	_____	_____

Date: _____
 Company Name: _____
 Ordered by: _____
 Account # (If applicable): _____
 Address: _____
 (street): _____
 (city): _____
 (state, zip code): _____
 Phone: _____

Send Parts to: (If you would like to send parts to a different location)

Company Name: _____
 Attn: _____
 Account # (if applicable): _____
 Address: _____
 (street): _____
 (city): _____
 (state, zip code): _____
 Phone: _____

Fax to:	United States	888-274-6192
	Canada	425-556-8659
	All other locations	1-425-895-6066